

Product data sheet

Characteristics

ILS1F851PC1A0

integrated drive ILS with stepper motor - 24..36 V
- CANopen DS301 - 5 A



Product availability: Non-Stock - Not normally stocked in distribution facility

Price*: 1250.00 USD



Main

Range of product	Lexium integrated drive
Product or component type	Motion integrated drive
Device short name	ILS
Motor type	3-phase stepper motor
Number of motor poles	6
Phase	Single phase
[Us] rated supply voltage	24 V 36 V
Network type	DC
Communication interface	CANopen DS301, Integrated
Length	5.54 In (140.6 mm)
Winding type	Medium speed of rotation and medium torque
Electrical connection	Industrial connector
Holding brake	Without
Gear box type	Without
Nominal speed	200 rpm 24 V 400 rpm 36 V
Nominal torque	17.70 Lbf.In (2 N.m)
Holding torque	17.70 Lbf.In (2 N.m)

Complementary

Transmission rate	50, 100, 125, 250, 500, 800 and 1000 kbauds
Mounting support	Flange 85 mm
Motor flange size	3.35 In (85 mm)
Number of motor stacks	1
Centring collar diameter	2.36 In (60 mm)
Centring collar depth	0.08 In (2 mm)
Number of mounting holes	4
Mounting holes diameter	0.26 In (6.5 mm)
Circle diameter of the mounting holes	3.90 In (99 mm)

Feedback type	Index pulse
Shaft end	Untapped
Second shaft	Without second shaft end
Shaft diameter	0.47 In (12 mm)
Shaft length	1.18 In (30 mm)
Supply voltage limits	18...40 V
Current consumption	5000 mA maximum
Associated fuse rating	10 A
Input/output type	4 signals (each be used as input or output)
Voltage state 0 guaranteed	-3...4.5 V
Voltage state 1 guaranteed	15...30 V
Discrete input current	10 MA at 24 V on/STO_A safety input 3 MA at 24 V on/STO_B safety input 2 MA at 24 V 24 V signal interface
Discrete output voltage	23...25 V
Maximum switching current	100 MA per output 200 MA total
Protection type	Safe torque off Overload of output voltage Short circuit of the output voltage
Peak stall torque	17.70 Lbf.In (2 N.m)
Continuous stall torque	17.70 Lbf.In (2 N.m)
Speed feedback resolution	20000 points/turn
Accuracy error	+/- 6 arc min
Rotor inertia	1.1 Kg.Cm ²
Maximum mechanical speed	2000 Rpm
Maximum radial force Fr	100 N
Maximum axial force Fa	170 N tensile force) 30 N force pressure)
Service life in hours	20000 H bearing
Marking	CE
Type of cooling	Natural convection
Net weight	5.73 Lb(US) (2.6 kg)

Environment

Standards	EN/IEC 61800-3 EN 61800-3:2001, second environment IEC 61800-3, Ed 2 EN 50347 EN 61800-3 : 2001-02 EN/IEC 50178 IEC 60072-1
Product certifications	CUL TÜV UL
Ambient air temperature for operation	122...149 °F (50...65 °C) with power derating of 2 % per °C) 32...122 °F (0...50 °C) without derating)
Permissible ambient air temperature around the device	221 °F (105 °C) power amplifier 230 °F (110 °C) motor
Ambient air temperature for storage	-13...158 °F (-25...70 °C)
Operating altitude	<= 1000 m without derating
Relative humidity	15...85 % without condensation
Vibration resistance	20 m/s ² 10...500 Hz) 10 cycles EN/IEC 60068-2-6
Shock resistance	150 m/s ² 1000 shocks EN/IEC 60068-2-29
IP degree of protection	Shaft bushing IP41 EN/IEC 60034-5 Total except shaft bushing IP54 EN/IEC 60034-5

Ordering and shipping details

Category	18288 - LEXIUM INTEGRATED DRIVES II
Discount Schedule	PC56
GTIN	03389119227124
Nbr. of units in pkg.	1
Package weight(Lbs)	6.61 Lb(US) (3 kg)
Returnability	No
Country of origin	DE

Packing Units

Unit Type of Package 1	PCE
Package 1 Height	4.13 In (10.5 cm)
Package 1 width	7.48 In (19 cm)
Package 1 Length	15.35 In (39 cm)

Offer Sustainability

Sustainable offer status	Green Premium product
California proposition 65	WARNING: This product can expose you to chemicals including: Lead and lead compounds, which is known to the State of California to cause cancer and birth defects or other reproductive harm. For more information go to www.P65Warnings.ca.gov
REACH Regulation	REACH Declaration
EU RoHS Directive	Pro-active compliance (Product out of EU RoHS legal scope) EU RoHS Declaration
Mercury free	Yes
RoHS exemption information	Yes
China RoHS Regulation	China RoHS Declaration
Environmental Disclosure	Product Environmental Profile
Circularity Profile	End Of Life Information
WEEE	The product must be disposed on European Union markets following specific waste collection and never end up in rubbish bins.
PVC free	Yes

Contractual warranty

Warranty	18 months
----------	-----------

Integrated Drive without Holding Brake

Dimensions

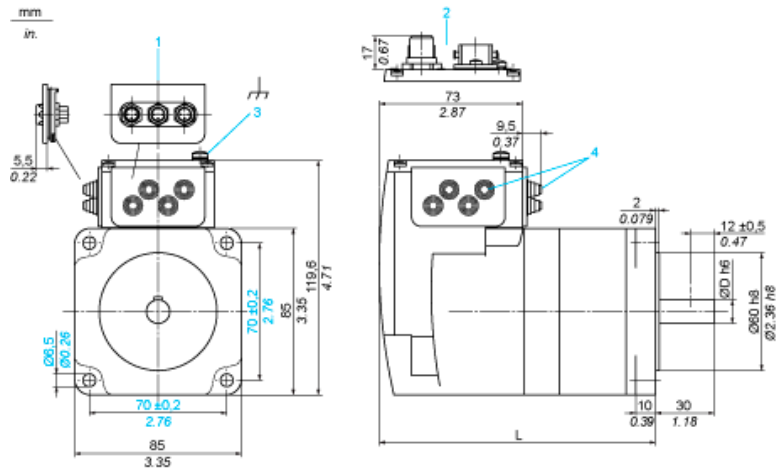

- 1 Accessories: I/O signal insert with industrial connectors
- 2 Option: industrial connectors
- 3 Earth (ground) terminal
- 4 Accessories: cable entries $\text{Ø} = 3 \dots 9 \text{ mm}/0.12 \dots 0.35 \text{ in.}$
- L 140.6 mm/5.53 in.
- D 12 mm/0.47 in.

Connection Example with 4 I/O Signals



Torque Characteristics

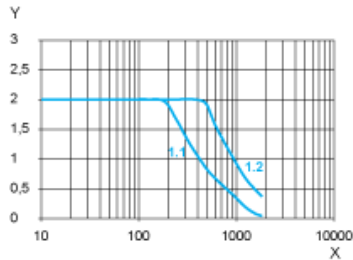

- X Speed of rotation in rpm
- Y Torque in Nm
- 1.1 Max. torque at 24 V
- 1.2 Max. torque at 36 V

Product Life Status : Commercialised